

LRC[®] AUTO-SEIZE[®] 90 & 180° ADAPTORS WITH TEST PORTS

Thomas & Betts 90 and 180 degree adaptors with test ports are designed for today's broadband network architectural demands and provide power passing reliability for future cable plant designs. This range of adaptors provides a superior connection and is easy to install, saving time in the field. The integral Auto-Seize mechanism allows for a high seizure force with pin connectors resulting in a more robust mechanical and electrical connection.

- Auto-Seize[®] grip design provides constant positive pressure to the pins of entry connectors.
- One step installation for entry connectors ensures a solid mechanical and electrical contact. The center conductor seizure screw connection is on longer required.
- The Auto-Seize[®] feature requires less installation time thus eliminates craft and sensitivity issues.
- Superior power capability up to 15 Amps minimum.
- The adaptor is environmentally sealed utilizing UV Ozone Resistant Ethylene Propylene O-rings.
- 5/8"-24 male/female interface.
- Test port allows access for voltage and signal level measurements.

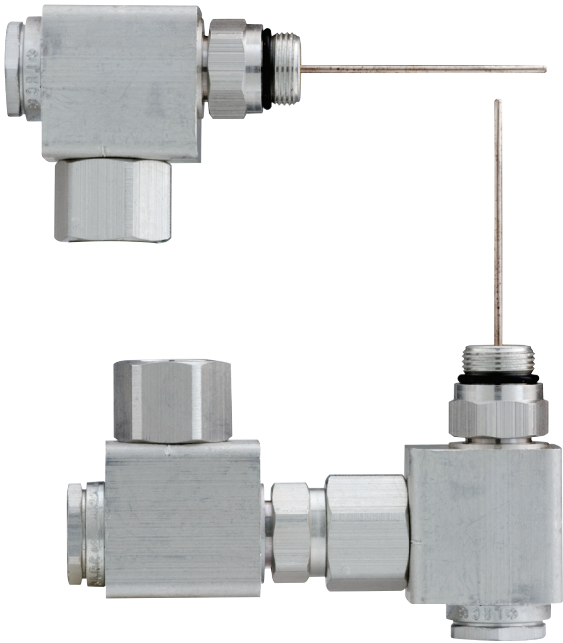

PHYSICAL PROPERTIES

- Body Components: Aluminum Alloy
- Body Finish: Chromate Conversion Coating
- Terminal: Brass, Silver Plate
- Entry Support: Ultem
- O-Rings: Ethylene Propylene

ELECTRICAL PROPERTIES

- Current Rating: 15 Amps
- Insulation Resistance: >20 Gigaohms @ 1,000 Volts
- Breakdown Voltage: 2.4 Kv
- Dielectric Strength: Complies to Bellcore GR-2846-CORE, Generic Requirements for Coaxial Distribution Connectors
- Return Loss: -30dB Typical
- Insertion Loss: -0.2 dB Typical
- RFI Shielding: -105 dB Typical

MECHANICAL PROPERTIES

- Entry Pin Insertion Force: 0
- Entry Pin Retention Force: 50 lbs Typical

ENVIRONMENTAL PROPERTIES

- Temperature Rating: -40°F (-40°C) to 140°F (60°C)
- Salt Spray Exposure: Complies to Bellcore GR-2846-CORE, Generic Requirements for Coaxial Distribution Connectors

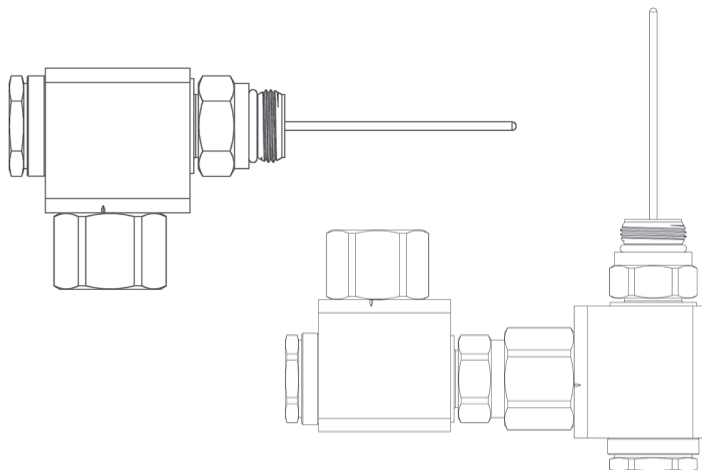

ORDERING INFORMATION

CATALOG NUMBER	DESCRIPTION	INNER PACK	OUTER PACK
LRC[®] AUTO-SEIZE[®] 90 & 180 DEGREE ADAPTORS WITH TEST PORTS			
EU90AST	90 degree Adaptor	8	96
EU90AST3	90 degree Adaptor with 3" Extension	8	64
EU180AST	180 degree Adaptor	8	64
EU180AST3	180 degree Adaptor with 3" Extension	8	64

Please ask your Thomas & Betts representative for a complete catalog of quality Thomas & Betts products or visit us at www.tnb.com. For customer service, call **1-800-685-9452**. For technical questions, call **1-888-862-3289**.

© 2007 Thomas & Betts Corporation. All rights reserved.

DATA SHEET # CDS-LRCAD90/180

Thomas & Betts Corporation
Communications Products Group
Tel: 800-920-0328 • 901-252-5000
Fax: 800-283-6756 • 901-252-1380